

MP-4V Heavy Duty Riveter / 39048



This newly designed heavy-duty air/hydraulic riveter is ergonomically designed with the professional in mind. The light weight 3.7 lbs. well balanced MP-4V includes a *Vacuum system* and is designed to maximize a 1" stroke and 3,420 lbs. of pulling force with a 3 jaw setup that gets the job done. The air supply can be connected directly or you can use the supplied swivel air connector with the attached hose for operator convenience. Each tool is supplied with nosepieces to set 5/32"- 1/4" rivets in all alloys. A 1/4" monobolt nosepiece is included in addition to adjustment service wrenches, hydraulic fluid, fluid applicator, spare jaws and an air off/on valve. The adjustable *Vacuum System* control knob located on the side of the tool allows you to control the force of the air needed to hold the rivet in place or you may operate the tool with the vacuum system turned off.

Recommended air pressure is 70-95 PSI.

**Alcoa
Fastening
Systems**



Alcoa Fastening Systems
1925 N MacArthur Dr.
Suite 200
Tracy, CA 95376



LA-534
07/2014

WARNING:
ALWAYS WEAR SAFETY GLASSES
WHEN OPERATING AND PERFORMING MAINTENANCE ON TOOL

AIR FEED

Use only compressed air. Check airline for damage from humidity & contaminants. In order to protect the tool from premature wear, we recommend the use of an in line moisture filter and air regulator.

Air inlet thread connection size on the tool is 1/4" NPT.

WARNING:

**Do not use air supply greater than recommended
or tool may be damaged or burst.**

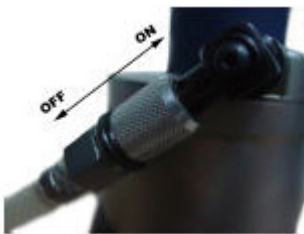

1. Connect air supply then switch ON/OFF valve to ON position

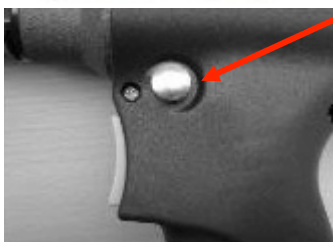

2. To turn on and adjust vacuum system rotate silver knob on side of tool and turn it clockwise until desired amount of vacuum is obtained to hold rivet in place and eject spent mandrel into the collection cup. If you don't want to use the vacuum system rotate the silver knob counter-clockwise to shut it off. The tool will still function but must be tilted backwards to allow spent mandrel to fall into collection cup.

ADDITION OF HYDRAULIC FLUID

1. Disconnect air supply to tool and switch ON/OFF valve to OFF position.

2. Remove seal screw and seal (see Fig. 3)

3. Screw the priming pump of filled oil into the bleed screw hole. Actuate the priming pump by pressing down and releasing several times until resistance is felt. (Fig. 4)

4. Remove the priming pump and the excessive oil will flow out. Wipe away and clean out the excessive oil and replace the seal and screw.



Fig 3



Fig 4

IMPORTANT: Use only Anti-Foam Hydraulic Fluid

CHANGING NOSEPIECES

1. After selecting the correct size nosepiece for the rivet being used Connect tool to air supply and pull trigger and hold trigger button.
2. Using wrench (supplied), unscrew nosepiece from frame head & replace with proper size nosepiece. Tighten down with wrench. **DO NOT OVERTIGHTEN.** Release trigger.

Your tool is now ready to work. Insert rivet mandrel into nosepiece. Insert rivet into predrilled hole in application and pull trigger button and hold until rivet sets then release the trigger. A second pull may be required.

CLEANING & CHANGING OF JAWS

With use, the jaws of the tool may become dirty or worn. This will cause slipping of the rivet mandrel & and improper setting of the rivet.

To clean the jaws follow this procedure.

1. Disconnect air supply.
2. Use a suitable wrench, unscrew frame head and remove.
3. Using a pair of wrenches, disassemble front jaw case from rear jaw case. DO NOT MOVE rear jaw case as this will affect tool operation.
4. To clean jaws, use a stiff dry wire brush.
5. If excessive wear is apparent, replace with new jaws.
6. Reassemble the jaw case assembly.

LIMITED TOOL WARRANTY

Alcoa Fastening Systems - Marson division warrants that this tool will be free from defects in material and workmanship under normal service and for ninety (90) days from the date of purchase.

This warranty applies to the purchaser of the tool for original use only.

All other warranties, whether expressed or implied, including any warranties of merchantability or fitness for purpose are hereby excluded.

Should this tool fail during this ninety (90) day period, and no unauthorized repairs have been made, return the tool freight prepaid to the factory for free of charge replacement of any part or parts found by Alcoa Fastening System - Marson division to be defective due to faulty material or workmanship. This represents the sole obligation of Alcoa Fastening Systems - Marson under this warranty. In no event shall Alcoa Fastening Systems - Marson division be liable for any consequential or special damages arising from the purchase or use of this tool. You may have other rights which vary from state to state.

IF further maintenance is beyond the scope of this manual and the tool fails to function properly, contact the factory or return it to the factory for service.

Contact our Tool Repair Center at 209-839-3032 for further information.

MP-4V BREAKDOWN & PARTS LIST

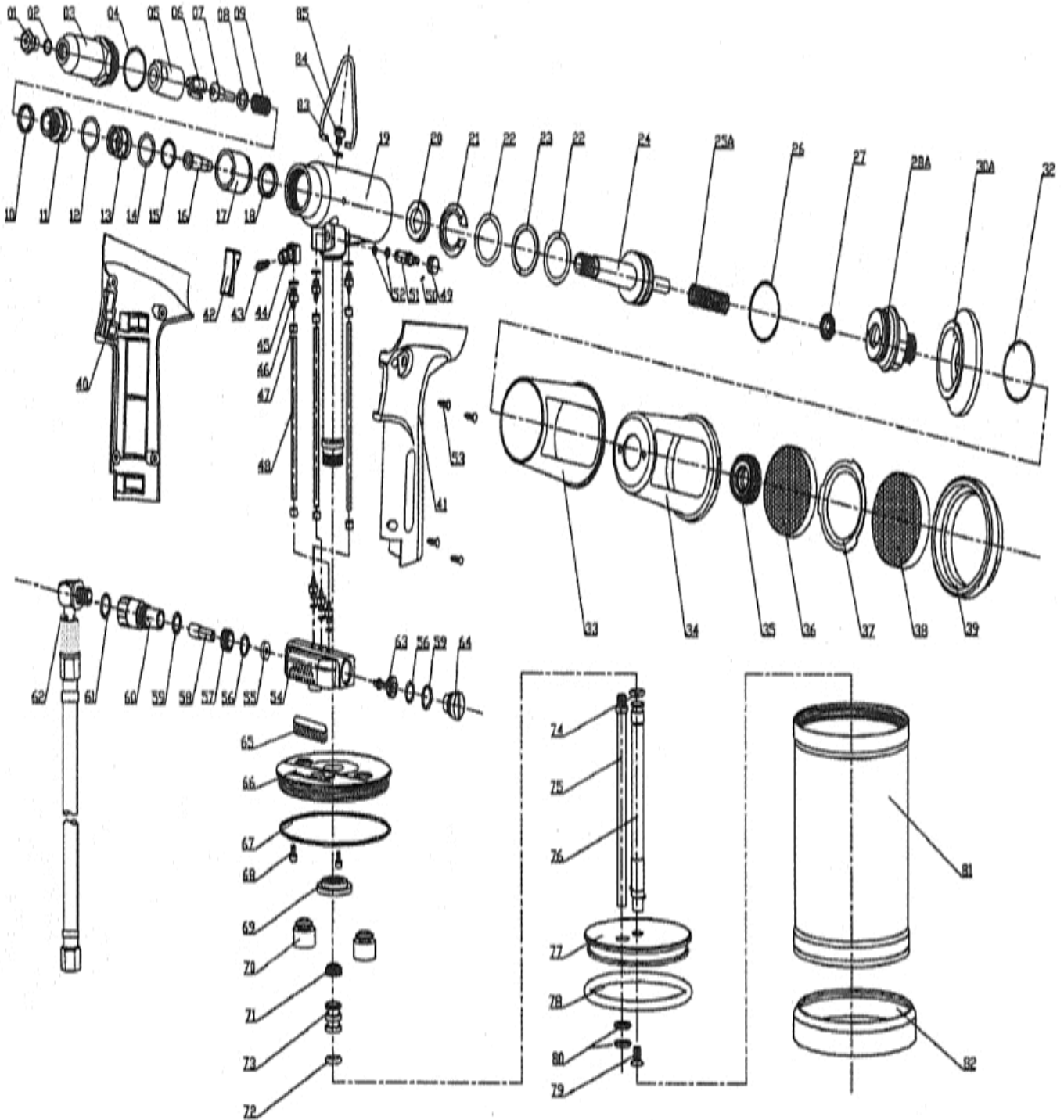

Ref. #	AFS Part #	Description
1	M95300	5/32" Nosepiece
1	M95301	3/16" Nosepiece
1	M95302	1/4" Nosepiece (Standard)
1	M95303	1/4" Nosepiece(Monobolt)
2	M95304	O-Ring 7x1
3	M95305	Nosepiece casing
4	M95306	O-Ring 18x2
5	M95307	Jaw housing
6	M95308	Jaws (3pcs)
7	M95309	Pusher
8	M95310	Washer
9	M95311	Jaw pusher spring
10	M95312	Lock ring
11	M95313	Housing
12	M95314	Polyurethane ring 12x2
13	M95315	Set nut
14	M95316	Polyurethane ring 14.3x2
15	M95317	O-Ring 13x1.5
16	M95318	Vacuum sleeve
17	M95319	Seal plastic housing
18	M95320	Sealing ring 20x13.5x3.5
19	M95321	Head assembly
20	M95322	U-Ring 14x22x6.3
21	M95323	Retaining nut
22	M95324	O-Ring 26.7x1.78
23	M95325	U-Ring 30x22x6
24	M95326	Principal Axis Unit
25A	M95327A	Spring
26	M95328	O-Ring 26.3x1.85
27	M95329	U-Ring 8x14.2x5
28A	M95330A	End cap
30A	M95332A	Stem collector adaptor
32	M95334	O-Ring 44x1.5
33	M95335	Stem collector outer
34	M95336	Stem Collector body
35	M95337	Retaining nut
36	M95338	Silencer
37	M95339	Stem collector end cap
38	M95340	Silence
39	M95341	Silencer cap
40	M95342	Handle (left)
41	M95343	Handle (right)
42	M95344	Trigger

Ref. #	AFS Part #	Description
43	M95345	Trigger valve
44	M95346	On/Off base
45	M95347	O-Ring 4x1
46	M95348	Air interface
47	M95349	Tie ring
48	M95350	Air tube
49	M95351	Regulator button
50	M95352	Retaining screw 3x3
51	M95353	Vacuum valve
52	M95347	O-Ring 4x1
53	M95355	Tapping screw 3x10
54	M95356	Air valve body
55	M95357	Air valve ring
56	M95358	O-Ring 9.5x1.5
57	M95359	Air valve base
58	M95360	Subordinate tube
59	M95361	O-Ring 11.5x1.5
60	M95362	Connecting base
61	M95363	O-Ring 9x2.4
62	M95364	On/Off assembly
63	M95365	Valve rod
64	M95366	Screw plug
65	M95367	Silencer
66	M95368	Cylinder cover
67	M95369	O-Ring 81.7x1.9
68	M95370	Bolt
69	M95371	Lock nut
70	M95372	Buffer
71	M95373	U-Ring 8x14x6
72	M95374	O-Ring 11.5x1.5
73	M95375	Air tube piston
74	M95376	Piston ring
75	M95377	Transfer tube
76	M95378	Piston rod
77	M95379	Cylinder piston
78	M95380	O-Ring 89.6x5.7
79	M95381	Bolt 6x10
80A	M95382A	O-Ring 7.8x1.9
81	M95383	Cylinder
82	M95384	Base cover
83	M95385	O-Ring 5.7x1
84	M95386	Seal screw
85	M95387	Hook
	M95290	Oil Priming Syringe