

39070 / **IL-1**

In-Line Air/Hydraulic Rivet Tool



GENERAL NOTES AND USE

The tool must be used for open end blind rivet diameters 3/32", 1/8", 5/32" and 3/16" only in all alloys. (aluminum, steel and stainless steel)

The **IL-1** oil / pneumatic system assures more power than comparable models. That means a reduction in the problems due to the wear and tear of the components, therefore, there will be an increase in reliability. The tool design adopted reduces the dimensions and the weight of the tool which makes it easy to use and gets the rivet into tighter and hard to reach areas.

SAFETY MEASURES AND REQUIREMENTS

All the operations must be done in conformity with the safety requirements, in order to avoid any consequence for your and other people’s safety and to allow the tool to work the best way.

• **Safety glasses must be worn when operating the tool.**

- Use equipment recommended in the maintenance chapter to do any maintenance and/or regulation of the tool.
- For topping up the oil, we suggest using only fluids in accordance with the features specified in this instruction sheet
- Repairing and cleaning operations must be done when the tool is disconnected from the air supplied source.
- If it is possible, we suggest hanging the tool from a **safety balancer**.
- Hearing protection is recommended when using tool
- Keep the tools in good conditions; do not remove either safety parts or silencers.

TECHNICAL DATA

- Working pressure.....6 BAR
- Min. int. diam. of the compressed air feeding hose.....Ø min = 6 mm
- Air consumption per cycle.....1.8 Lt.
- Max power.....6 BAR = 2100 lb
- Weight.....3.65 Lb
- Working temperature.....25F/120F

AIR FEED

The air feed must be free from blockage and humidity in order to protect the tool from premature wear and tear of the components in movement. We recommend to use a filter / regulator / lubricating system for compressed air to achieve the best results.

HOW TO USE YOUR RIVETING TOOL

Select correct nosepiece for the rivet to be used. Place rivet in predrilled or punched hole. Squeeze trigger. After the rivet is upset, the sheared mandrel is drawn through by the riveting tool and is ejected from the back into the nail deviator (A).

To activate the vacuum system or increase the suction turn the valve (B) counterclockwise. The advantage of this vacuum system allows the head of the riveting tool to be pointed vertically while holding the rivet in place. Do not hold the rivet with your fingers!

WARNING!! Do not remove the nail deviator (A) during the riveting operation, as the nail ejection from the back of the tool can cause injury to yourself or to others nearby.

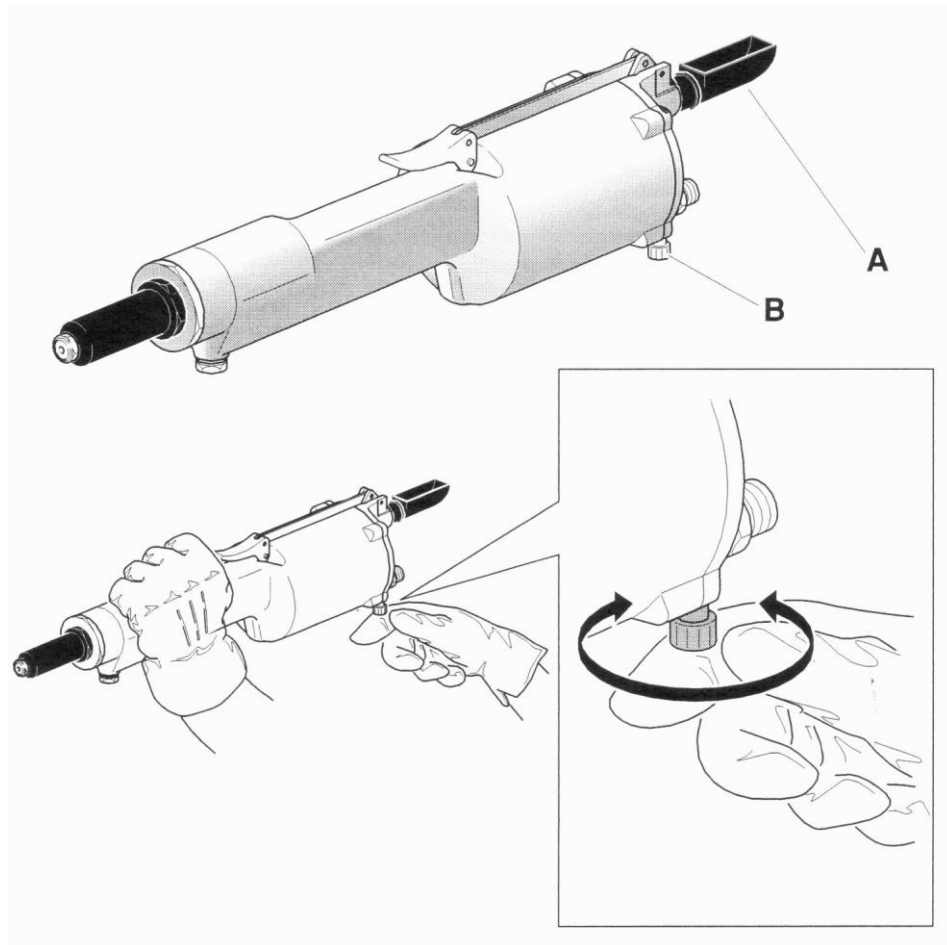

If you want to convey the sheared nails into a container, remove the nail deviator **(A)** and its reducer **(B)** from the riveting tool. Connect a 5/16" hose **(C)** to the riveting tool introducing it into the union **(D)**.

ATTENTION: the bending radius of the pipe should not be smaller than 12 inches and it should not be higher than 8 inches compared to the riveting tool, as shown in the picture.

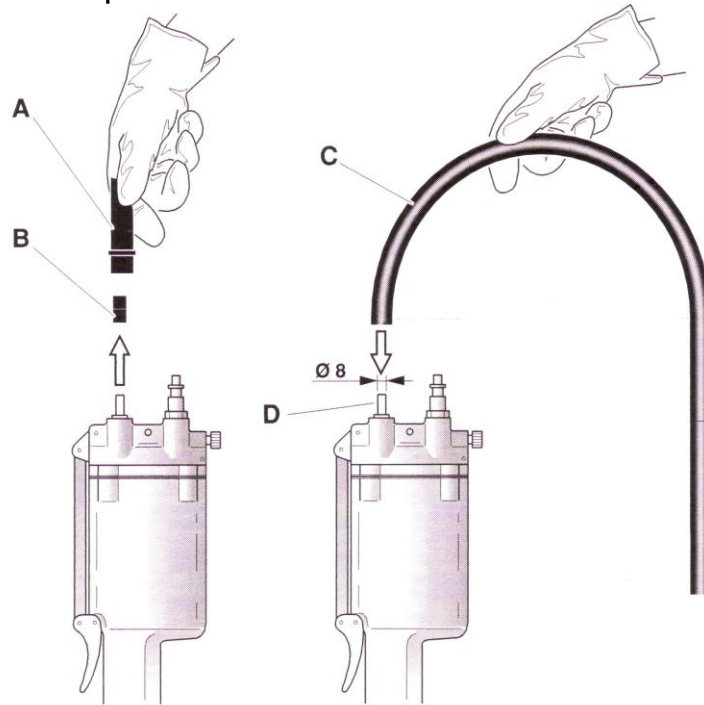

MAINTENANCE

WARNING!!! DISCONNECT AIR FEED WHEN PERFORMING THE FOLLOWING OPERATIONS!

The extended use of the tool can cause the slipping of the Jaws on the mandrel due to material build up into the grooves of the Jaw. Clean Jaw thoroughly with a wire brush to clean any debris in grooves. Apply a light coat of oil to the outside of the Jaws and reassemble.

However, if Jaws are worn out , replace them.

First remove the Frame Head which holds the nosepiece **(A)**, by means of a standard 1-1/16" wrench. Then, by using two wrenches of 11/16" (17mm) and 5/8" (16mm) remove the Jaw Case **(B)** and remove the Jaws **(C)**. When replacing the nosepiece **(D)**, we recommend to use the Wrench provided.

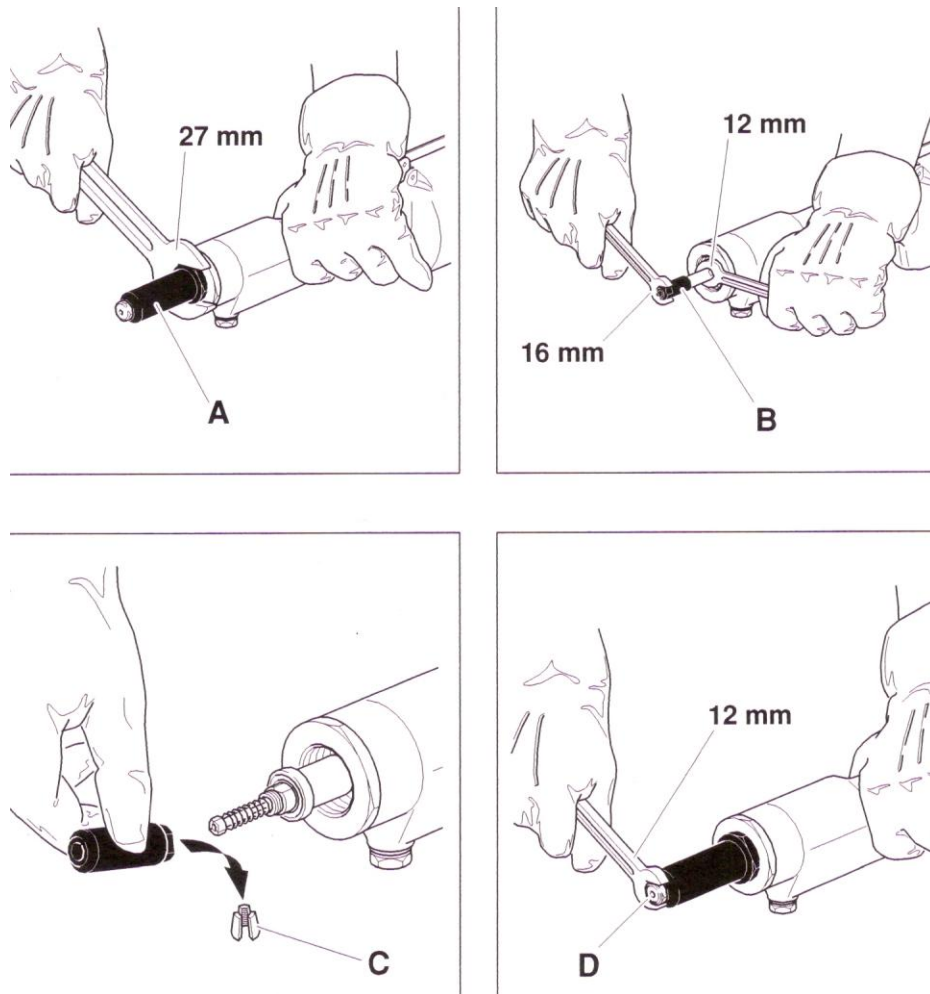

TOPPING OFF HYDRAULIC FLUID

WARNING!!! DISCONNECT AIR FEED WHEN PERFORMING THE FOLLOWING OPERATIONS

You need to top off the oil-dynamic circuit after a long period of work or a notice of some stroke loss. Proceed as follows: by means of a short jet of compressed air through hole **(C)** to make the piston completely go back. Unscrew the screw **(A)** with a 15/32" wrench, extract the seal and top off by means of the oil container **(B)** supplied with the tool (VISCOSITY 32°). This operation has to be carried out slowly in order to enable the air to come out of the tank. The procedure has been fulfilled when the oil level arrives at the threaded port. Then, fit the o-ring in it's seat and tighten the screw **(A)** with a torque of **min. 5 Nm to max. 8 Nm**. At this point, the topping off operation has been finished.

Screw the riveting tool head **(B)** again on the body **(A)** and continue with the normal work cycle. **WARNING:** it is very important to follow the about mentioned instructions and use gloves. If you need to empty fully the hydraulic circuit, you must put the oil in a suitable container and contact a Company that is authorized to discharge any waste.

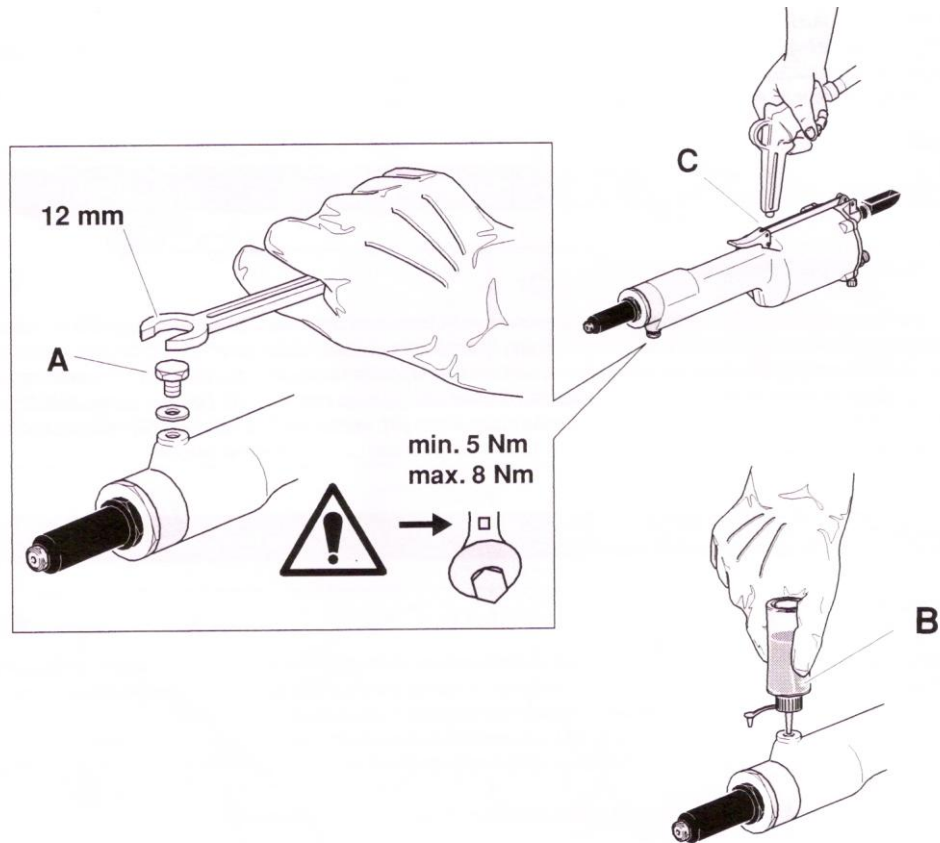

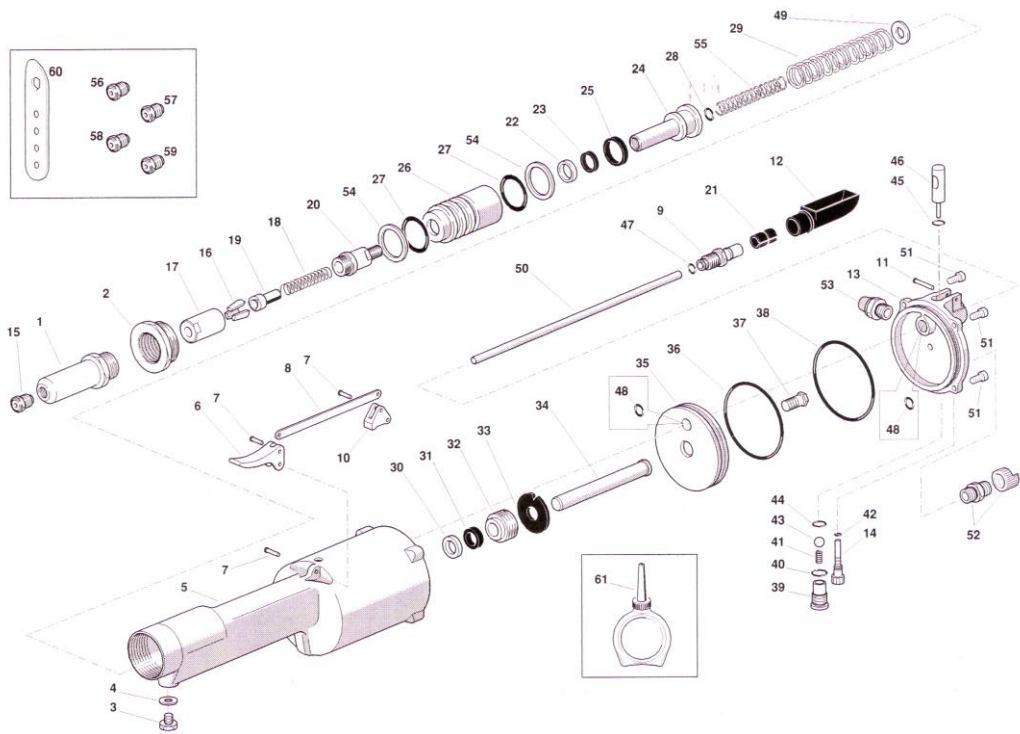

Parts List for 39070 IL-1

Ref #	Item #	Qty	Description	Ref #	Item #	Qty	Description
1	88056	1	Head Carrying Nozzle	32	712322	1	Ring nut
2	712342	1	Ring nut	33	712321	1	Air Piston Stop
3	710554	1	Cap	34	712320	1	Air Piston Rod
4	710555	1	Washer Dowtry 400-004-4490	35	722319	1	Air Piston
5	712341	1	Tool body	36	712318	1	Air Piston O'Ring
6	712340	1	Push Button	37	88004	1	Screw Stem
7	712337	3	Trigger Set Pin	38	712317	1	Cylinder Cap O'Ring
8	712338	1	Trigger Rod	39	712316	1	Spring guide plug
9	712334	1	Connector	40	88321	1	O Ring 2-12 P
10	712339	1	Rod Holder	41	712315	1	Spring
11	712335	1	Trigger Rod Set Pin	42	88023	1	Valve/Frame ORing (X3)
12	712283	1	Guard	43	710377	1	Ball RB-8
13	722333	1	Bottom	44	712314	1	O Ring 2-107
14	712332	1	Vacuum adjustment knob	45	712313	1	O Ring 2-104
15	88055	1	3/16" Nosepiece	46	712312	1	Piston
16	88058	3	Jaws	47	710003	1	O Ring 5-052
17	88057	1	Jaw Case	48	710002	2	O Ring 2-108
18	88026	1	Jaw Pusher spring	49	712416	1	Washer 9.4x20x1.5
19	88059	1	Jaw Pusher	50	712293	1	Vacuum Tube
20	712331	1	Rear Jaw Case	51	710303	4	Screw TCE M5x16 UNI 5931
21	712329	1	Reducer	52	88040	1	Milled nut connector 1/4
22	712330	1	Piston guide	53	712343	1	Silencer 2 SEM 1/4" M
23	88068	1	Stem Guide	54	88220-94	2	O-Ring Spacer 8-121
24	712328	1	Piston	55	712327	1	Interior Spring
25	88668	1	Gasket	56	717001	1	1/8" Nosepiece
26	712326	1	Oil dynamic cylinder	57	717002	1	5/32" Nosepiece
27	88210-12	2	O Ring 2-121 N552/90 P	58	717003	1	3/16" Nosepiece for Closed End Rivets
28	716060	1	O Ring 2-10	59	717006	1	3/32" Nos3piece
29	712325	1	Exterior Spring	60	88220-78	1	Nosepiece Holder / Wrench
30	712324	1	Stem Guide	61	710969	1	Oil container
31	712315	1	Spring				

